



V-Series Model V3 Automatic Screen Filter

V3 Filter Specifications

General Information

The V-Series Model V3's design is the most recent, state-of-the-art self-cleaning screen filtration technology available today. The complexity and cleaning efficiency of any self-cleaning screen filter is in the mechanical system that drives the cleaning process. The new V-Series® patent protected Vacleen™ Reverser drive mechanism is the simplest and most efficient in design resulting in:

- fewer moving parts (no limit switches or pistons reversing the cleaning mechanism),
- simpler controls,
- lowest flush waste available,
- greater cleaning efficiency, and
- lower maintenance requirements.

The V-Series Model V3's 10 to 30 second flush cycle is automatically initiated when a pressure differential across the screen increases to 7 psi. The filter remains on line, and the filtration process remains uninterrupted during the cleaning process. And the flush discharge is the lowest available resulting in minimal waste.

The V-Series filters are constructed to ASME code and are designed to incorporate a broad range of construction materials, pressure and temperature options. VAF custom manufactures filters and skids that simplify installation and meet specific requirements.

Materials

- | | |
|-------------|---------------------------------|
| Filter body | • 8" - 14" inlet/outlet, 316 SS |
| Screens | • 316L SS sintered ** |
| Flanges | • AWWA Class D ** |
| Seals | • nitrile, viton, silicone ** |

- | | |
|-------------------------|------------------------|
| Filtration Range | • 15 to 1500 micron ** |
|-------------------------|------------------------|

- | | |
|-------------------|---|
| Flow Range | • 150 to 2,040 gpm per filter
(with 130 micron screen) |
|-------------------|---|

- | | |
|---------------------|---|
| Max Pressure | • 150 psi (10.5 kg/cm ²) ** |
|---------------------|---|

- | | |
|---------------------|---------------------------------------|
| Min Pressure | • 35 psi (2.5 kg/cm ²) ** |
|---------------------|---------------------------------------|

- | | |
|-----------------|--------------------|
| Max Temp | • 176° F (80°C) ** |
|-----------------|--------------------|

- | | |
|--------------------|--------------------|
| Flush Cycle | • 10 to 30 seconds |
|--------------------|--------------------|

- | | |
|------------------------|---|
| Control Options | • VF1B - battery powered, single filter |
| | • VF -AC - electronic, up to 12 filters |
| | • VF-PFC - fully-programmable, electronic, multiple interface options |

** Other options are available on request.

Dimensions

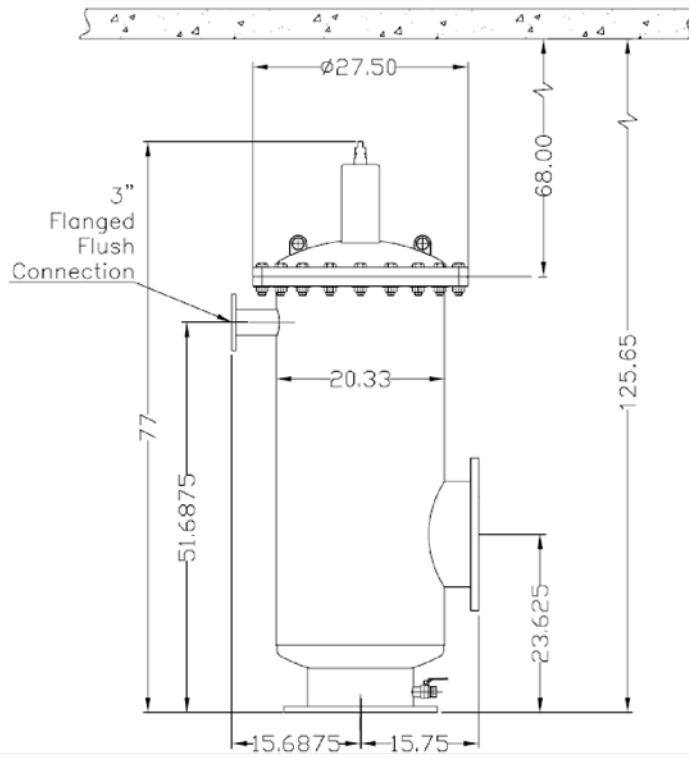

Model	flush line AWWA Class D flanges	inlet/outlet 8-10-12-14	top clearance in	screen area in ²	nominal flow (gpm)			flush flow gallons	# of nozzles
					100 μ	200 μ	300 μ		
V3	3"	8-10-12-14	68.0	1,696	2040	2720	3060	33	6

Note: Valve and Filter "nominal flow" rates are for 100, 200 and 300 micron filtration ratings for demonstration purposes only. Larger micron ratings result in higher allowable flow rates. Smaller micron ratings result in lower allowable flow rates. Call Valve and Filter for details.

Typical Application

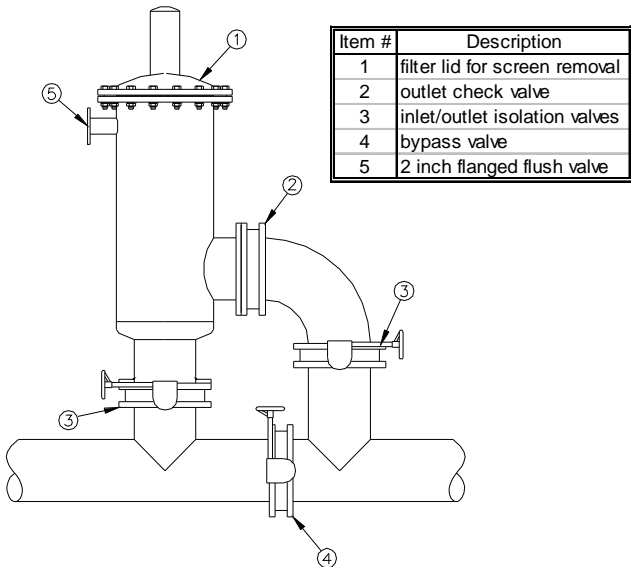

How To Order

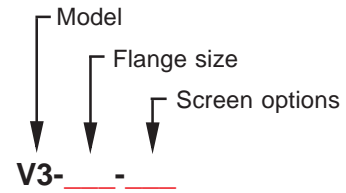

OPTIONS:

<u>Models</u>	<u>Flange sizes</u>	<u>Screen options</u> **
V3	8, 10, 12 or 14	15, 25, 50, 75, 100, 120, 180, 200, 300, 400, 800, or 1500 micron all models

** Other micron on special request.

Distributed By:



ISC Sales
4421 Tradition Trail
Plano, TX 75093
877-602-0010
www.isliquidfiltration.com

VAF Filtration Systems, LTD