

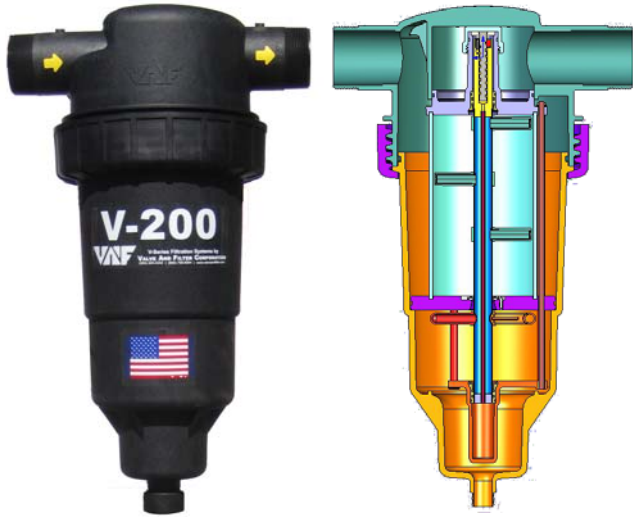

FILTRATION SYSTEMS



V-200PA Automatic Screen Filter

Award Winning



V-200PA Specifications

General Information

The new V-200PA features the most advanced and cost effective self-cleaning screen filtration technology available today. Ideal for flow rates from 20 gpm (1.3 lps) to 220 gpm (13.9 lps); the V-200PA offers a cost effective solution for automatic filtration down to 10 micron.

The new V-Series® patented drive mechanism used in the V-200PA is the most efficient and simplistic design available resulting in:

- fewer moving parts,
- simpler controls,
- the lowest flush flow rates and volumes available,
- high cleaning efficiencies; cleans in one pass,
- very low maintenance requirements.

The V-200PA is constructed using glass reinforced nylon and 316L stainless steel. The inherent corrosion resistance of these materials ensures a long service life under a wide range of water quality conditions including seawater.

The V-Series' 10 to 15 second flush cycle is automatically initiated when a pressure differential across the screen increases to a maximum of 7 psi (45 kPa). The filter remains on-line, and the filtration process remains uninterrupted during the cleaning process. The flush discharge is the lowest available resulting in minimal waste.

The V-200PA is perfectly suited for process water, cooling tower filtration, pre-filtration of membrane, irrigation, or wherever suspended solids are removed down to 10 micron.

When installed with a hydraulic controller and diaphragm valve, the filtration system operates completely with line-pressure without requiring any electricity. The ideal solution for remote filtration applications.

Materials

- | | |
|-------------|--|
| Filter body | <ul style="list-style-type: none">• 3" NPT inlet/outlet• 3" BSP inlet/outlet• Glass reinforced Nylon |
| Screens | <ul style="list-style-type: none">• 316L SS sintered ** |

Filtration Range • 10 to 1500 micron **

Flow Range • 20 to 220 gpm per filter
• 1.3 to 13.9 l/s per filter

Max Pressure • 150 psi (1034 kPa) **

Min Pressure • 30 psi (206 kPa) **

Max Temp • 140° F (60° C) **

Flush Cycle • 10 to 15 seconds

Control Options

- VF1-H - single filter hydraulic controller, does not require electricity.
- VF1-B - battery powered, single filter
- VF-AC - electronic, up to 12 filters
- VF-PFC - programmable, electronic, data logging, multiple interface options

** Other options are available on request.

Specifications and Dimensions

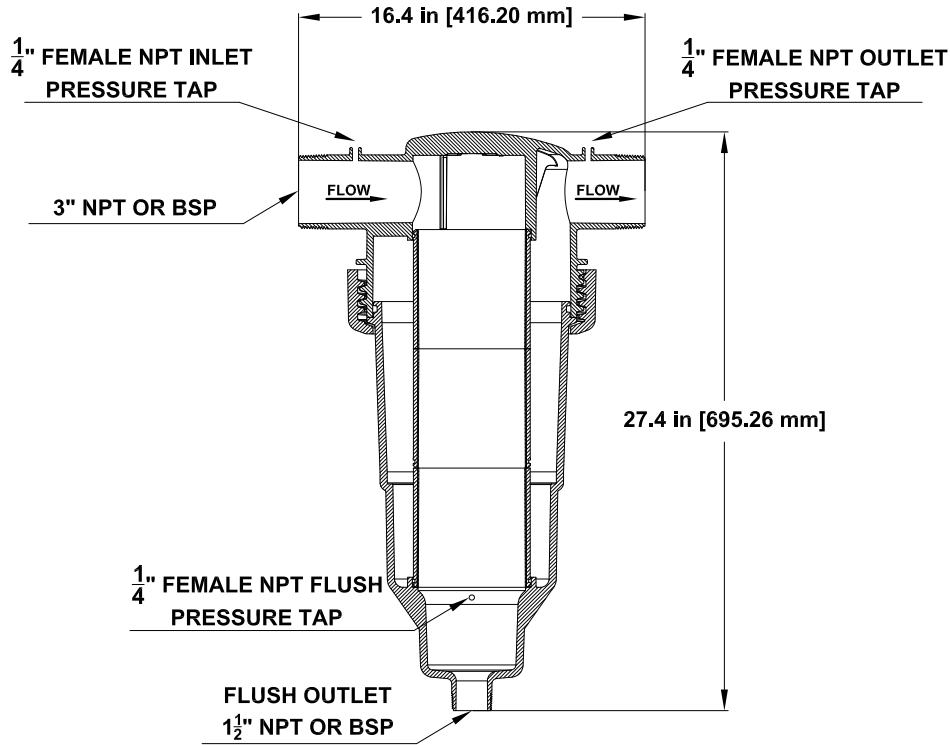

Model	Screen Area		Nominal Flow				Flush Flow (10 sec.)		# of Nozzles	Dry Weight
	in ²	cm ²	50 micron (270 mesh)	80 micron (200 mesh)	100 micron (150 mesh)	120 micron + coarser (120 mesh)	gal	liter		
V-200P	175	1130	131gpm / 8.3lps	158gpm / 9.9lps	193gpm / 12.1lps	220gpm / 13.9lps	4	15	3	25lbs / 10kg

Nominal Flow rates shown above are for demonstration purposes only. Smaller micron ratings result in lower allowable flow rates. Call Valve and Filter for details. Dimensions are approximate, please contact Valve and Filter for drawings.

Flow Information

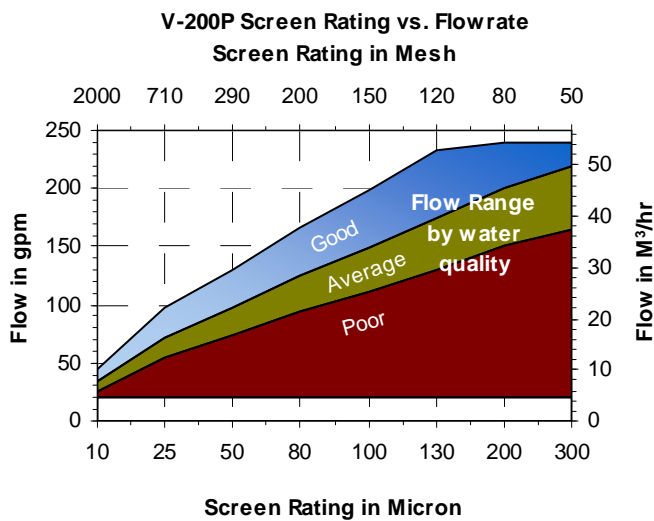

How To Order

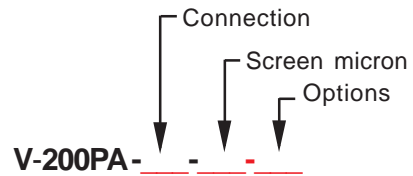

STYLES

A - Automatic self-cleaning screen filter

CONNECTIONS

3" NPT - 3N
3" BSP - 3B

SCREEN MICRON**

50, 80, 100,
120, 200, 300

OPTIONS

PK - Pressure Kit, includes 2 glycerine filled gages and fittings.
EN - Expanded metal enclosure to protect outdoor installations.
YS - Wye strainer for use with systems with 1/8" or larger particulate.

** Microns shown are in stock.
Other microns available

Distributed By:



ISC Sales

4421 Tradition Trail
Plano, TX 75093
877-602-0010
www.isliquidfiltration.com

VAF Filtration Systems, LTD