



36FOS and 52FOS **Multi Cartridge Housings**

Our thirty six and fifty-two round models are designed for flow rates up to 1040 GPM. Housings accept double-open-end style cartridges. Options include 304L or 316L stainless steel with swing bolt closure and lifting davit. Design pressure 150 psi (10 bar) @ 300° F (149° C). Standard inlet and outlet connections for the 36 & 52 FOS series is 6" flanged, with many other options available by special order. Standard finish is Poly-coat over stainless. All thirty six and fifty-two round models are standard with heavy duty stainless steel mounting legs and FDA grade Buna-N gasket.

Features

- Designed for industrial and commercial filtration needs
- Heavy duty stainless steel construction for durability
- 304L standard and 316L stainless steel available
- Heavy duty swing-bolt closure for quick cartridge change outs
- All stainless steel heavy duty mounting legs standard
- Pipe fittings readily accessible for easy installation
- Knife edge seal at both cartridge ends to eliminate by-pass
- Adjustable top plate for more cartridge options
- Adapters for 222 or 226 style cartridges available by special order.
- Complete selection of pipe fittings, flanged, sanitary, BSP, grooved and others
- See ordering guide for a complete selection of options to fit your application

Standard Design Specifications

Model	No. & (Length) of Cartridges†	Flow Rate GPM*	Flange Size	Drains	Vent	Max Ctg Diameter•	Shipping Weight
36FOS3	36 (30")	540	6F	3/4" NPT	1/2" NPT	2 5/8" OD	321 lbs
36FOS4	36 (40")	720	6F	3/4" NPT	1/2" NPT	2 5/8" OD	375 lbs
52FOS3	52 (30")	780	6F	3/4" NPT	1/2" NPT	2 5/8" OD	543 lbs
52FOS4	52 (40")	1,040	6F	3/4" NPT	1/2" NPT	2 5/8" OD	591 lbs

†Housings will accept: 30" = (29 1/4" or 30") 40" = (39" or 40") Lengths

*Flow rates are for guide lines only. Actual flow rates are based on fluid, viscosity, cartridge type, micron ratings and other factors.

• When using 222 or 226 adapters with the 36 FOS series housing you must change it to a 32 FOS (32 Round) max cartridge OD 2 3/4"
When using 222 or 226 adapters with the 52 FOS series housing you must change it to a 50 FOS (50 Round) max cartridge OD 2 3/4"

Dimensions

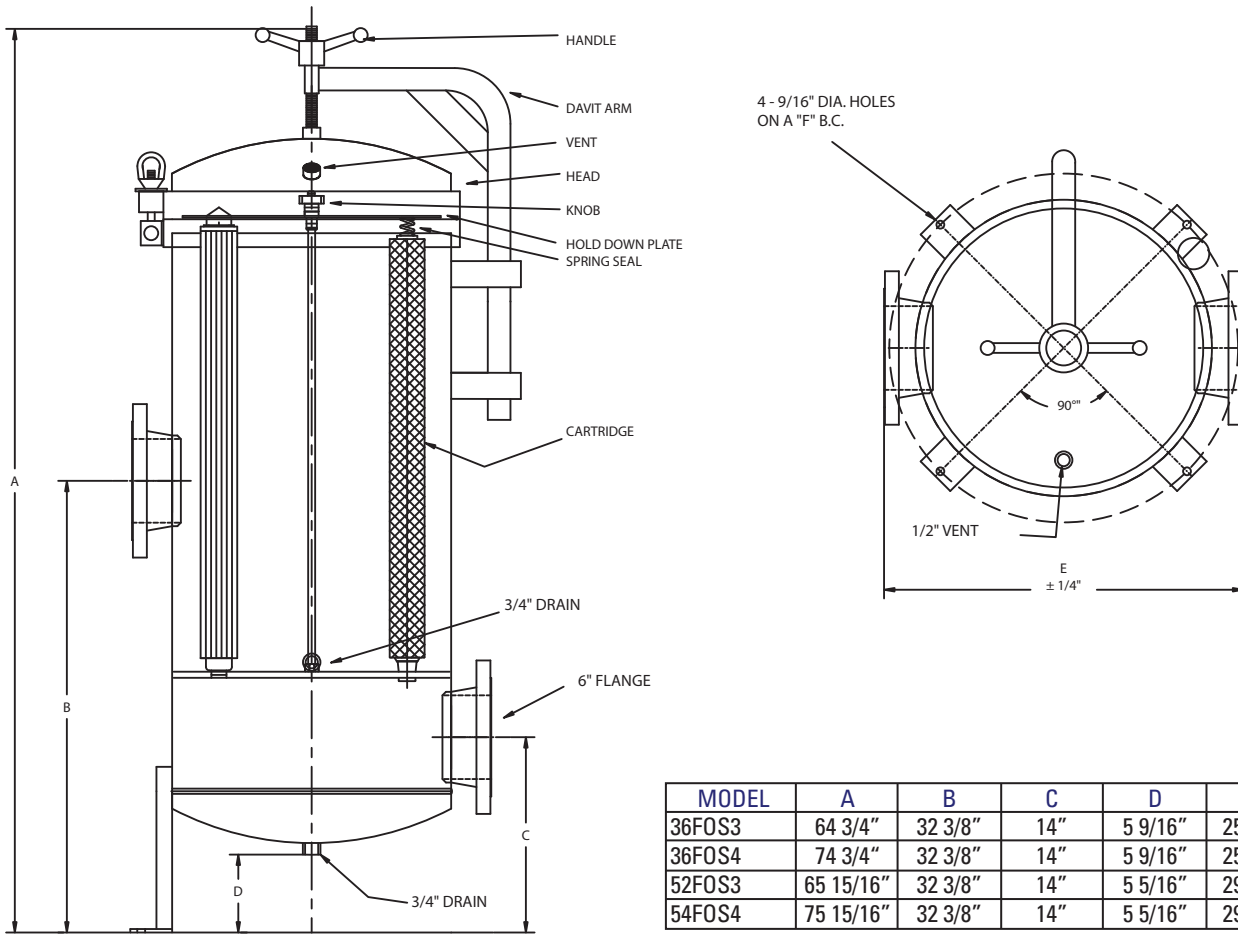

MODEL	A	B	C	D	E	F
36FOS3	64 3/4"	32 3/8"	14"	5 9/16"	25 7/8"	25"
36FOS4	74 3/4"	32 3/8"	14"	5 9/16"	25 7/8"	25"
52FOS3	65 15/16"	32 3/8"	14"	5 5/16"	29 7/8"	26"
54FOS4	75 15/16"	32 3/8"	14"	5 5/16"	29 7/8"	26"

ORDERING GUIDE

36 FOS 3 - SB - 316 - DOE - 6F - EP - GP - E									
No. of Columns	Product Code	No. of Stacks	Closure Style	Material	Cartridge Configuration	Connection Type	Finish	Options	Gasket
36 52	FOS	3 = 3 High 4 = 4 High	SB = Swing Bolt	Blank = 304L 316 = 316L	Blank = Double Open Ended •222 = 222 Style Cartridge Fin or Flat •226 = 226 Style Cartridge Fin or Flat	Blank = 6" Flanged OPTIONS 6TC = 6" Ferrules 6GF = 6" Grooved Fittings 8F = 8" Flanged 8GF = 8" Grooved Fittings	Blank = Standard Poly Coat EP = Electro-Polished GB = Glass Bead P = Passivate	Blank = None GP = Gauge ports GPA = Gauge ports with gauges	Blank = Buna E = EPR S = Silicone V = Viton TS = Teflon Encapsulated Silicone



Shelco manufactures a complete Line of elements for your application